

# SD SERIES SMALL DRYING HOPPERS



## SD SERIES SMALL DRYING HOPPERS

SD Series drying hoppers are available in machine-mount and floor-mount configurations. They feature unique mass-flow design, full hopper insulation, and slide gate shut-off. Large door allows for easy cleanout.

## STANDARD FEATURES

- Unique mass flow design
- Stainless steel construction (inside and out)
- Hinged access door (3.0 cu. ft. [85 liter] and larger models) (Hinged access door on 1.7 cu. ft. [50 liter] model is optional)
- Dual-wall insulated cylinder and cone section
- Slide gate
- Extended length sight glass on the hopper door

## OPTIONAL FEATURES

- Handle kit with casters for floor stand (SD 0.40 - SD 9.0 floor-mount models only)
- Floor stand (less casters)
- Cart to mount 1 drying hopper and 1 AD/ASD/AC/ACM Series dryer
- Cover selections: SRC/SLC, SRH/SRL, manual fill, or blank
- Hopper loader mounting bracket
- Gaylord fill stand, including slide gate. Requires 50" (127 cm) clearance
- Adjustable proximity switch
- Flange with special mounting holes
- Cover with special bolt pattern
- Drain port (standard for machine mount units)<sup>1</sup>

ACS Group • Walton/Stout is committed to a continuing program of product improvement. Dimensions are subject to change without notice.

© 2009 ACS Group • Walton/Stout

Bulletin WMH1-140

Printed in USA

**WS**  
ACS GROUP • WALTON/STOUT

ACS Group • Walton/Stout  
2900 S. 160th Street  
New Berlin, WI 53151

Phone: 262-641-8600  
Fax: 262-641-8653  
Email: [waltonstout@waltonstout.com](mailto:waltonstout@waltonstout.com)

[www.waltonstout.com](http://www.waltonstout.com)

# SD SERIES SMALL DRYING HOPPERS



## PORTABLE CARTS

Portable carts are available to mount 1 drying hopper to an AD or ACM cabinet-style dryer.

4" diameter heavy-duty casters are standard on portable carts. Specify square slide gate with or without 10" TOC adapter.

## ADDITIONAL FEATURES

- Smooth surface
- No material hangups
- Easy to clean
- Large access door with sight glass

## DIMENSIONS

Drying Hopper	A	B	C	D
SD-0.40	18	11	1.5	25
SD-0.85	25	14	2 1/2	25
SD-1.7	34	14	2 1/2	25
SD-3.0	38	22	2 1/2	25
SD-4.0	44	22	2 1/2	25
SD-6.0	56	22	2 1/2	25
SD-9.0	68	22	2 1/2	25

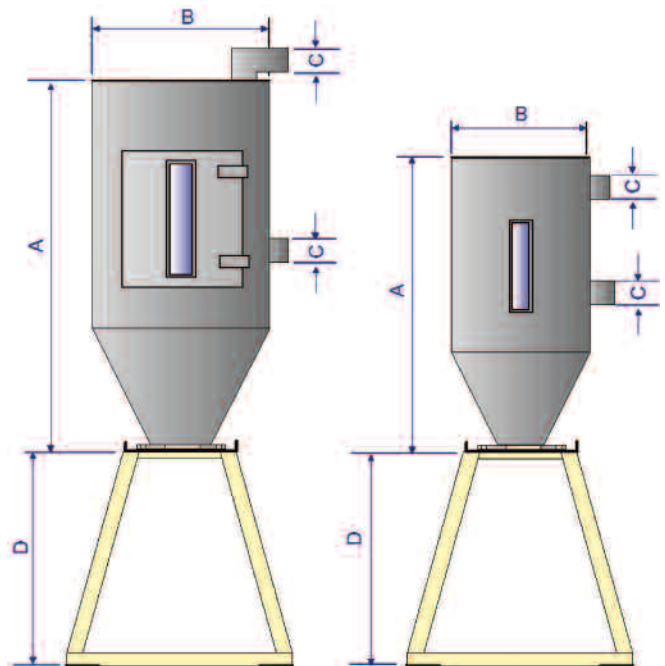

ACS Group • Walton/Stout is committed to a continuing program of product improvement. Dimensions are subject to change without notice.

© 2009 ACS Group • Walton/Stout

Bulletin WMH1-140

Printed in USA

# WS

ACS GROUP • WALTON/STOUT

ACS Group • Walton/Stout  
2900 S. 160th Street  
New Berlin, WI 53151

Phone: 262-641-8600  
Fax: 262-641-8653  
Email: waltonstout@waltonstout.com

[www.waltonstout.com](http://www.waltonstout.com)