

CTS SERIES WATER COOLING AND RECOVERY

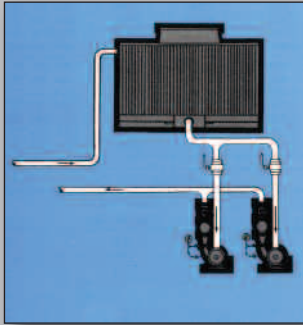

Tower Pump Reservoir

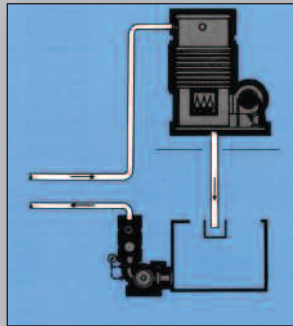

Indoor Reservoir with Single Compartment

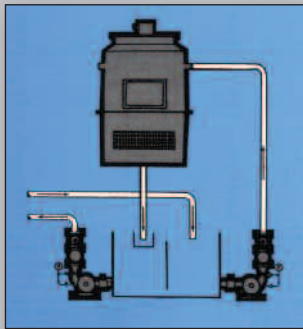

Indoor Reservoir with Double Compartment

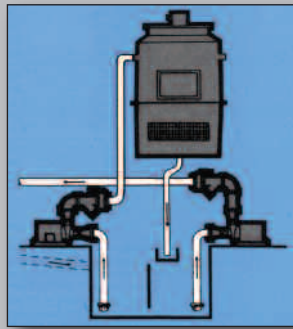

Double Pump with Gravity Return Reservoir

CTS Water Cooling and Recovery Systems are shipped complete and include cooling tower(s), epoxy lined and painted steel or rotomolded polyethylene reservoir assembly with close-coupled pump and trim mounted in place. The pump includes suction shut-off valve, check valve, throttling device and gauge trim in accordance with ACS Group • Walton/Stout pump and trim specification. Tank legs, push button starter(s), thermostat(s), thermometer(s), valves, strainer basket are included. The "M" models have Metal towers. The "P" models have Polymer towers. The "F" models have Fiberglass towers.

INDOOR RESERVOIR WITH DOUBLE COMPARTMENT

Double compartment reservoirs with separate process and recirculating pumps maintain a constant water flow between the tank and tower. This arrangement is recommended where widely fluctuating loads are common, or where loads will vary and partial system capacity will be utilized. It also assures positive freeze protection and consistent tank water temperature control under partial load.

INDOOR RESERVOIR WITH SINGLE COMPARTMENT

Indoor water reservoir with single compartment can operate in cold climates without danger of freezing. This system is widely used where flow conditions are relatively constant. The standard design condition for 100% tower efficiency in this arrangement is 3 gpm per ton of cooling tower capacity.

DOUBLE PUMP WITH GRAVITY RETURN RESERVOIR

Below grade reservoirs with double compartments and separate process and recirculating pumps are normally used in process cooling applications where zero back pressure is required. This system is also suited to fluctuating cooling loads, or where only partial system capacity will be utilized.

TOWER SUMP RESERVOIR

System using cooling tower basin as water reservoir. The double pump arrangement in this system provides downtime protection and is recommended for high volume pumping application. The tower sump reservoir is only recommended for warm climate process cooling or summer air conditioning condenser water applications.

ACS Group • Walton/Stout is committed to a continuing program of product improvement. Dimensions are subject to change without notice.

© 2009 ACS Group • Walton/Stout

Bulletin WHC6-135

Printed in USA

WST

ACS GROUP • WALTON/STOUT

ACS Group • Walton/Stout
2900 S. 160th Street
New Berlin, WI 53151

Phone: 262-641-8600
Fax: 262-641-8653
Email: waltonstout@waltonstout.com

www.waltonstout.com